

# SCOOTER 4060



- Outside panels in st/st
- Oven shipped in 2 preassembled elements (fast installation) or completely assembled (as option)
- 9 shelves not removable rack supplied as standard (extractable optional)
- FAST AIR automatic steam exhaust system
- Burner for natural gas or LPG included in the overall dimensions of the oven (SC) (optional)
- Heat generator with armored electric elements (SE)
- Automatic start
- Faceplate/hood without fan
- Double glass door capable of opening up to 160°
- N.3 halogen lamps in the baking chamber
- Electric board included in the overall dimensions of the oven, inside the base (or proofer)
- Integrated air steam condenser (optional)
- Burner or electric elements on the right side (optional)
- Steam generator with liter-counter (optional)
- Base or proof box on wheels

## PROOF BOX

- Armored electric element with thermostat for heating
- Water basin with electric element for humidity
- Inner ventilation for even air distribution
- Digital keyboard supplied as standard
- Humidity regulation and control with probe

POWER INLET	400/3N~/50 Scooter 230/1~/50 cella
WATER INLET	Diametro 1/2"
GAS PIPE INLET	Diametro 1/2"
FUMES EXHAUST	Diametro 120 mm
STEAM EXHAUST	Diametro 120 mm

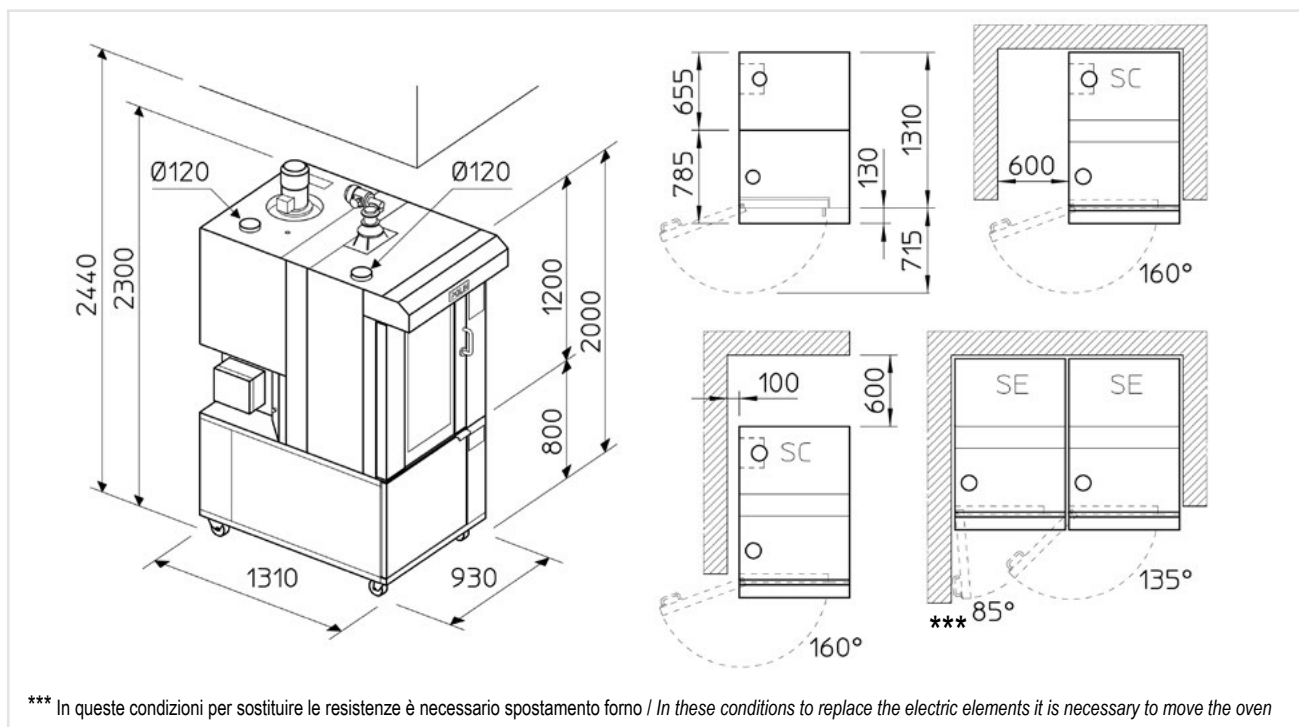

	Pan capacity		Pan size	Minimum door width	Weight	SC Version		SE Version
	n°	passo	mm	mm		kW	kcal/h	kW
<b>SCOOTER 4060/9 SC</b>	7	115	400x600	800	300	1,4	18.000	-
<b>SCOOTER 4060/9 SE</b>	9	90	460x600	(930*)				15,1**
<b>CELL</b>	14	80	400x600	670	80			2,0

\* Overall dimensions of the completely assembled oven (930x1440 H=2300 mm)

\*\* With steam generator (18,6 Kw)

