

STRATOS OLD STYLE



- Oven shipped completely assembled (steam generators excluded)
- N.3 bakings chambers h18
- St/st armored heating elements
- Independent front elements
- "DIGIT 01/E" digital keyboard with special functions for energy saving control.
- Automatic start (for each deck)
- Steel baking plates.
- Max temperature 380 °C.
- Safety thermostat for each deck and each steam generator (steam generators optional)
- Hood with 3.speeds exhaust fan
- Baking plates in "fibre-cement" (optional - max 300°C recommended for baking bread, pastry, etc.).
- "Armored concrete" baking plates (optional - recommended for baking on trays pizza, focaccia, etc.).
- "Refractory" baking plates (optional - recommended for free bake of pizza, focaccia, etc.).
- Wheels H=80mm (optional)
- Electric board preset for one power connection (optional)

FRONT CHARACTERISTICS

- Electrocolored front in St/st Aisi 304
- Brass plated accessories
 - Thermometers with frame
 - Chamber doors with handle
 - Steam exhaust valve with handle
 - Old style plate on the hood-
- Hidden digital key-board (Front door)
- Box for wood storage
- Termometer with hands
- Front cristal with black serigraphy arch shape

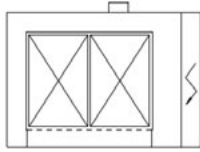
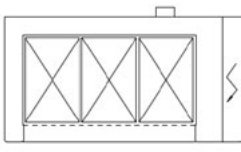
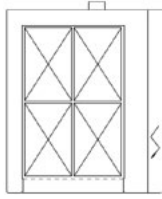
2STA 4060 N°2 40X60	3STA 4060 N°3 40X60	4ST 4060 N°4 40X60
		
n°5 pizze Ø30	n°8 pizze Ø30	n°11 pizze Ø30

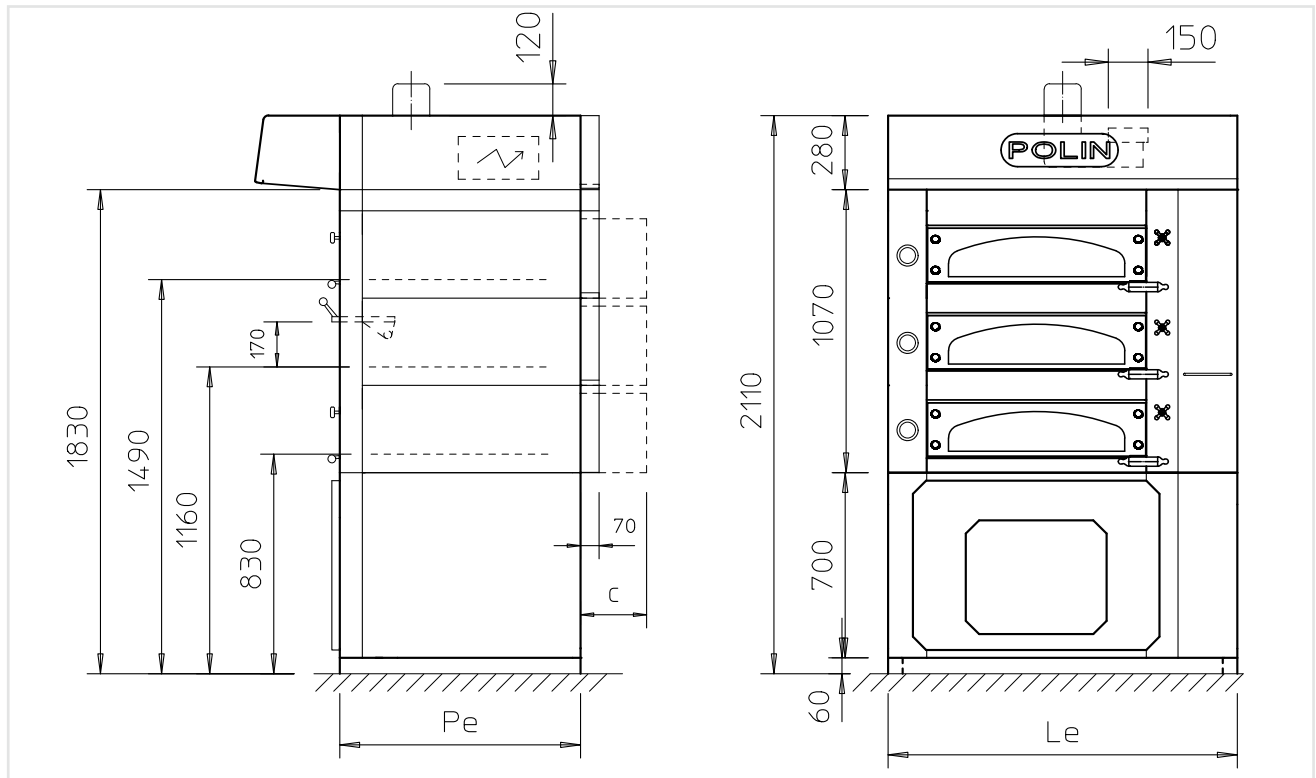

	LE	PE	LI	PI	Weight	C	Power	Super Power
	mm	mm	mm	mm	kg	mm	kW	kW
2STA 4060	1320	910	830	640	800	250	13,6	22,6
3STA 4060	1730	910	1240	640	1000	250	19,9	33,4
4ST 4060	1320	1510	830	1240	1100	250	22	39,7

